

SATECH Modular Protection Systems

Custom guarding and associated products



SATECH
Modular Machine Guards



SCHMERSAL
THE DNA OF SAFETY

Two companies...

SATECH

SATECH is an Italian company with an 12,000 square meter design, development, and manufacturing facility in Calco, in the province of Lecco. Established in the year 2000, SATECH quickly became a European market leader in modular protection systems for industrial machinery.

Their focus is on guarding systems constructed of low carbon steel. Upright posts and panel frame members are a solid extrusion for extra durability. Fence mesh is constructed by 2 mm diameter steel wire, arc welded at each junction. The construction methods utilized make the assembled system highly impact resistant.

Since SATECH exclusively operates in the industrial sector, its technical department is geared up to meet customers' individual requirements and provide customized protection equipment and systems for different industry sectors. Ongoing technical research and development, coupled with years of experience, enable SATECH to provide the right solution whatever the application.



SCHMERSAL

For 70 years Schmersal has earned a reputation for the design and manufacture of quality safety products and innovation remains paramount as we continuously produce new products to meet the demands of the ever evolving industrial sector. The company is headquartered in Germany, with 6 manufacturing sites and branch offices in over 20 countries worldwide.

Today the Schmersal product portfolio contains over 25,000 products, including keyed interlocks, solenoid locks, electronic safety switches and sensors, coded magnet sensors, safety hinge switches, safety light curtains, safety rated limit switches, safety edges and mats, and a wide assortment of safety controllers. We also offer industrial grade automation switches and control devices.

Our vast working knowledge of local and international standards has allowed Schmersal in North America to lead the way in helping customers understand the requirements for specific applications. Our trained machine safety engineers are available to guide customers through the maze of safety standards that are seen today.

... working together for complete safety solutions

Schmersal North America is pleased to offer SATECH modular guarding systems in the US and Canada. Our wide array of machine safeguarding switches, sensors and control accessories complement SATECH's modular guarding systems. Whether it is a simple application or a complex safety system, Schmersal can help you design the perfect SATECH guard and provide all the necessary safety devices to meet relevant machine guarding standards. Together, we offer complete safety solutions for all machine safeguarding needs.

Contents



System Design	
System Features	4
AutoCAD Design	5
System Components	
Basic Series Posts	6
Strong Series Posts	7
Modular Panels	8
Wire Mesh Panel Details	9
Doors	10
Accessories	11
Guard Monitoring and Controls	12
Relevant Standards	14

System Feature Highlights

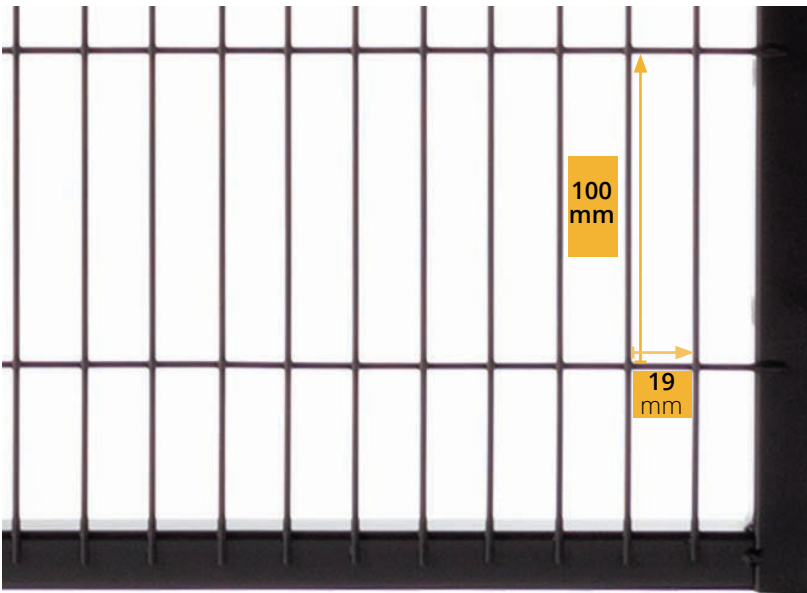

Designed with standards in mind:

Safety EN ISO 13857
A 19 mm slot width allows the installation of the fence only 120 mm from the danger zone.

Anti-climbing EN ISO 14120-5.18
External vertical wires limit toeholds and effectively deter climbing.

Visibility EN ISO 14120-5.9
The vertical slots and black painted finish ensure excellent visibility of the machinery through the wire mesh panel.



Panel Connections

Following the update of the European machine safety directive 2006/42/CE, SATECH has developed patented captive fastening systems for its complete range of products. Satech offers two types of panel connections:



- Patented captive bolt system, using pre-drilled holes in the upright posts and panel frames.



- Patented adjustable clamps which slide onto the posts. The clamps offer remarkable time savings during assembly and height adjustment. They also allow easy reinstallation of the guard after it has been removed for non-routine maintenance.

The wire mesh can be custom cut, on site, to fit around machine parts

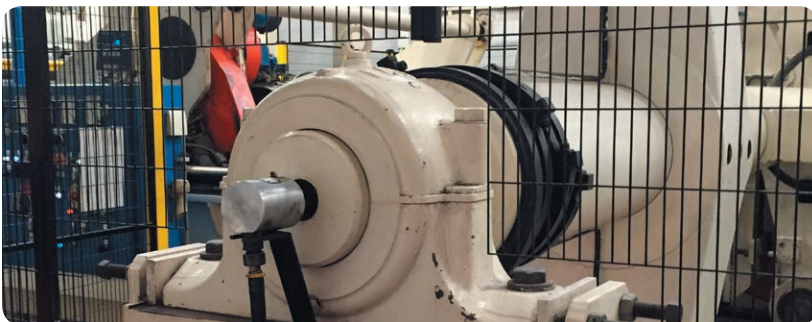

Packaging and shipping

SATECH has taken great care in the design of protective packaging for products in transit, to ensure they arrive in perfect condition. This has been achieved by an innovative vertical pallet system which minimises packaging materials and maximises space in the delivery vehicle – keeping shipping costs low and protecting the environment.



Design Services

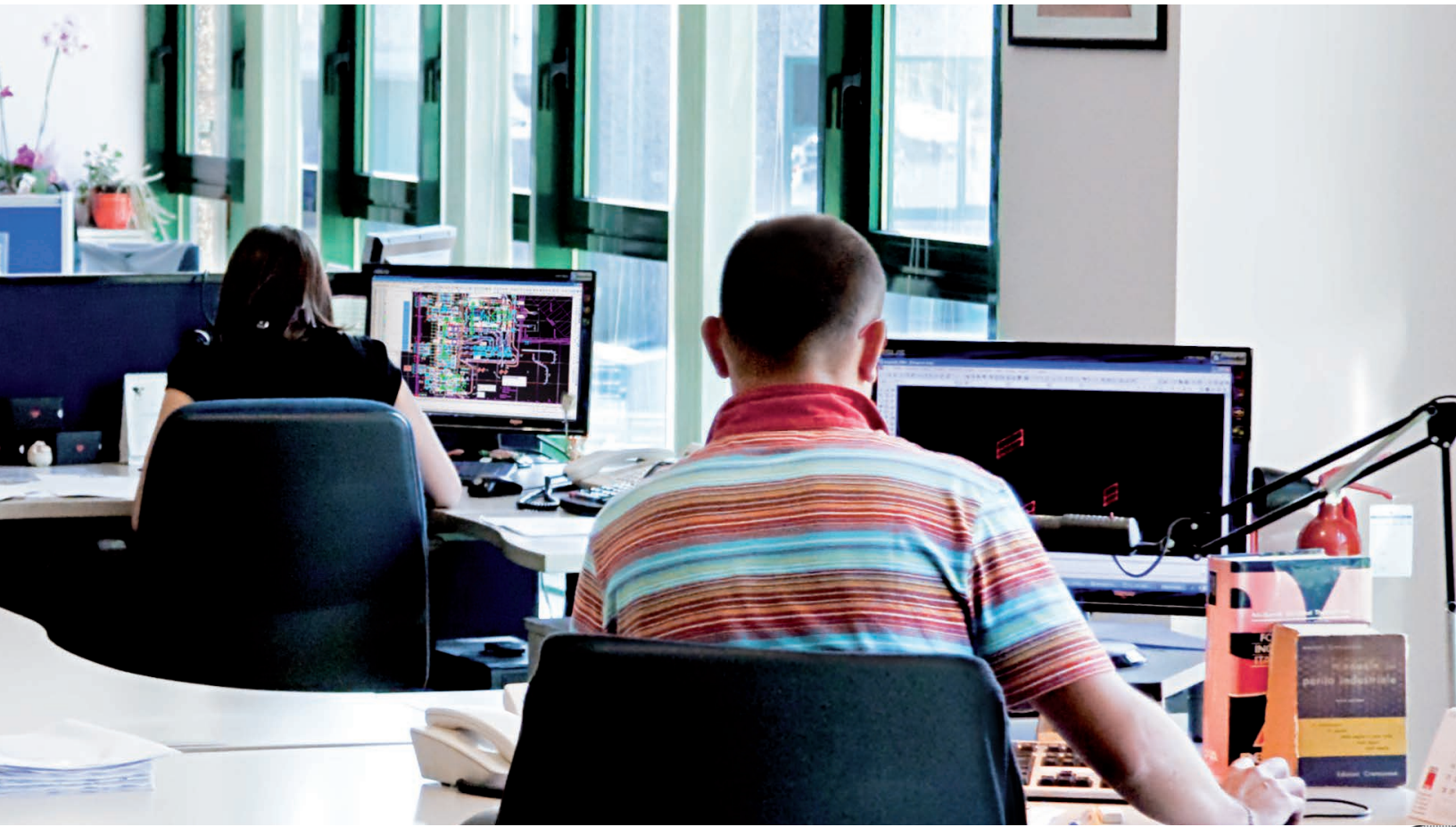

SATECH has invested substantially in software for the automatic 3D design of modular guards. This allows for the optimal selection of panels and the provision of a 3D drawing that is easily understood by assembly personnel.

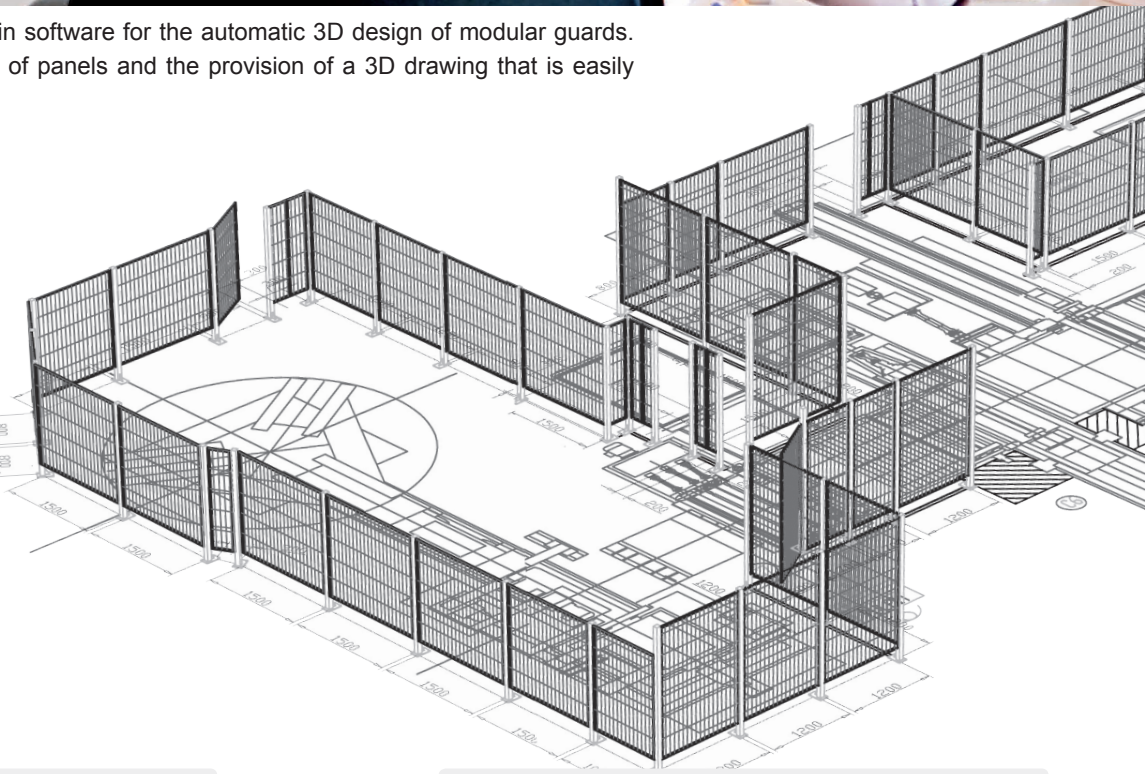
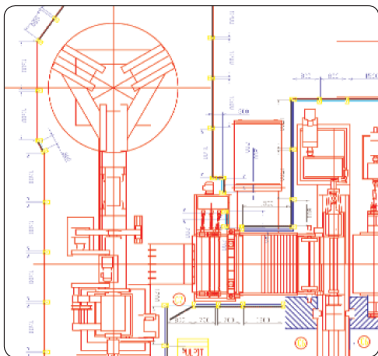

Realistic execution:

The layout is designed directly on the customer's drawing – which immediately highlights any conflicts with the plant layout.

Isometric layout view:

The installers work from an isometric drawing which avoids any possible confusion as to positioning of the protection components and equipment.

Basic Series Posts

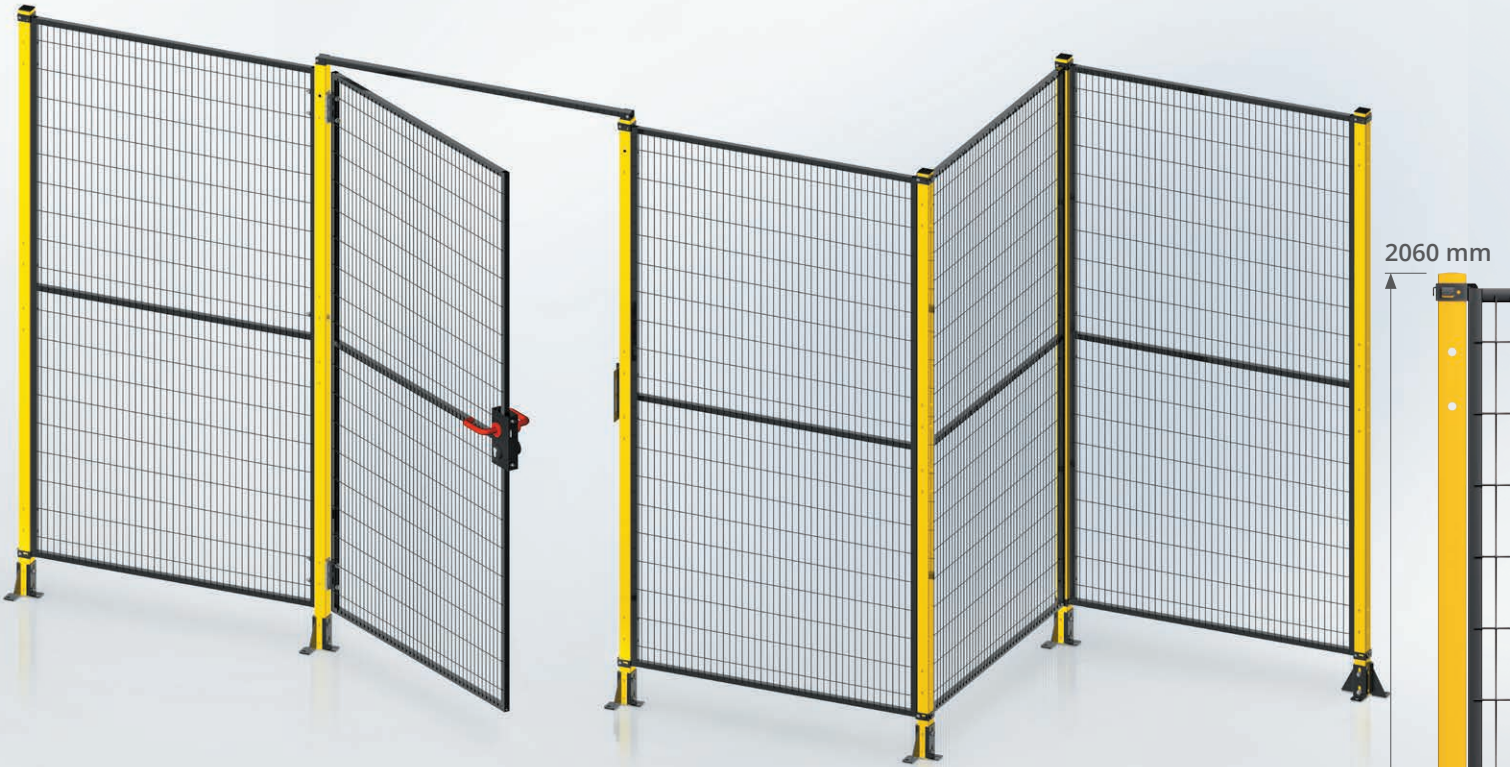

Perimeter Protection Series: BASIC

This is the standard system used in guards for plant and machinery. Protection and accident prevention system consisting of 40 x 40 mm uprights and wire mesh panels with 20 x 20 mm frames, connected by bolts or SATECH patented fast assembly clamps.



Watch an introduction video on YouTube

2060 mm tall posts,
Connection with bolt
Part code: PLR2060



2060 mm tall posts,
Connection with clamps
Part code: P0L2060

BASIC Post profile
40 x 40 mm
2 mm thickness
(actual size)

Finish:
Epoxy-polyester powder
(suitable for internal use only)

Standard color:  RAL 1021
Other colors possible,
consult factory for
custom finishes

Post footings:
Adjustable brackets

A pair of floor mount brackets are bolted to the upright post, allowing for leveling.

The brackets provide 3 drilled anchor points to ensure stability.



Strong Series Posts

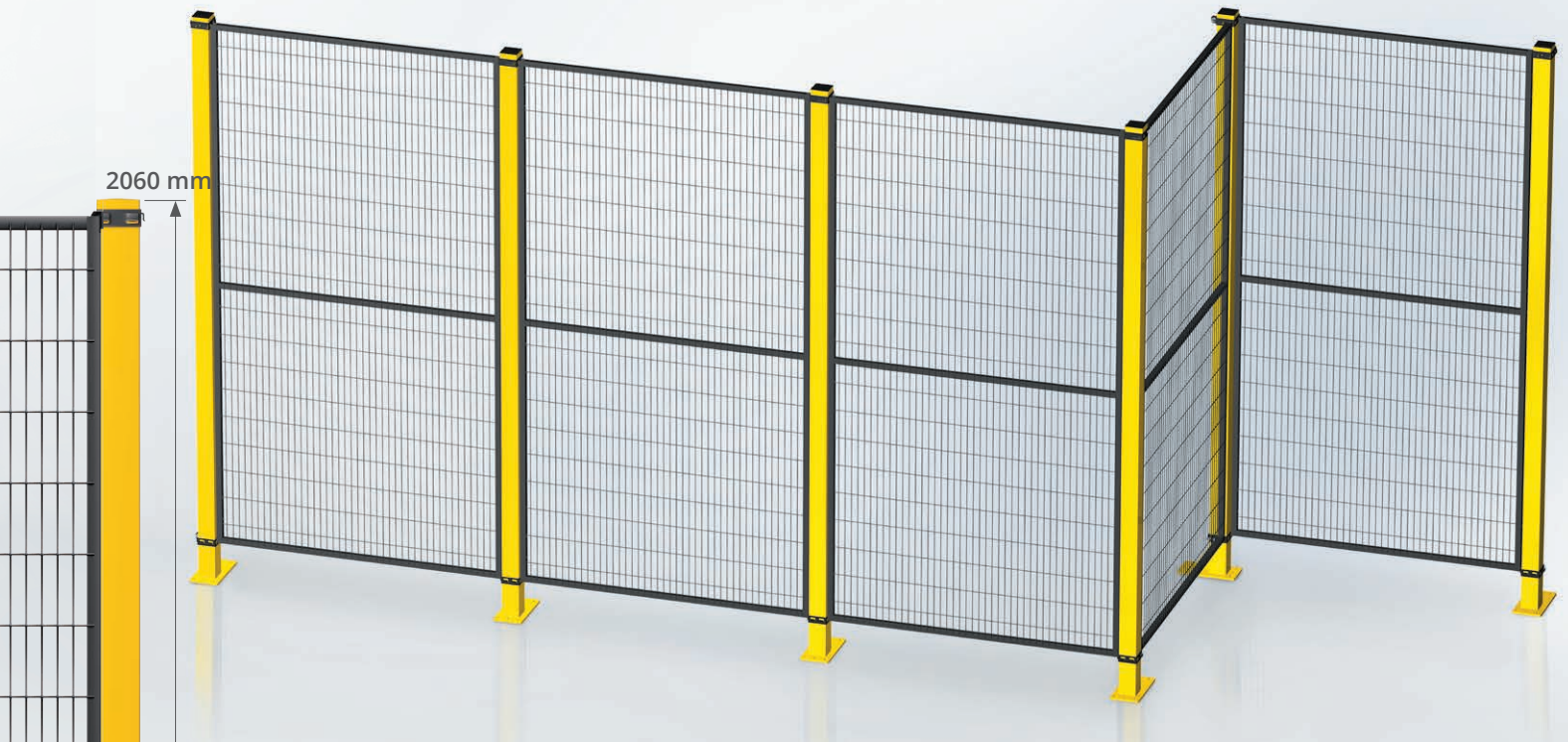

Perimeter Protection Series: STRONG

This series is used in heavier applications such as industrial robotics or the steel industry. Protection and accident prevention system consisting of 60 x 60 mm uprights and wire mesh panels with 20 x 20 mm frames, connected by bolts or SATECH patented fast assembly clamps.



Watch an introduction video on YouTube

2060 mm tall posts,
Connection with bolt
Part code: HFT2060



2060 mm tall posts,
Connection with clamps
Part code: H0L2060



Post footings:

Base plate

Generously sized base plates (100 x 200 mm and 8 mm thick) with 4 drilled anchor points, welded to the upright post to ensure stability.

STRONG Post profile
60 x 60 mm
2 mm thickness
(actual size)

Finish:
Epoxy-polyester powder
(suitable for internal use only)

Standard color:  RAL 1021
Other colors possible, consult factory for custom finishes

Modular Panels



Modularity

Stocked panels are 1900 mm tall and available in 7 standard widths:

200, 300, 700, 800, 1000, 1200, 1500 mm

Combinations of these standard widths reach the intermediate dimensions, in 100 mm steps. Panels can be bolted to each other to fill the required spacing between posts.

The factory can also provide panels 960, 1260, or 1500 mm tall.

If necessary, panels can also be cut to length or height on site and finished with the cutting kit:



Cutting Kit

The standard panels can be reduced in height or width by cutting the frame and mesh wires. The panel cutting kit consists of a cut-to-size frame tube, a U-profile and a set of self-drilling screws. The adapted panel remains fit to be assembled on all SATECH systems, without welding.

Panel Combinations	
200	200
300	300
400	200 200
500	200 300
600	300 300
700	700
800	800
900	700 200
1000	1000
1100	800 300
1200	1200
1300	1000 300
1400	700 700
1500	1500

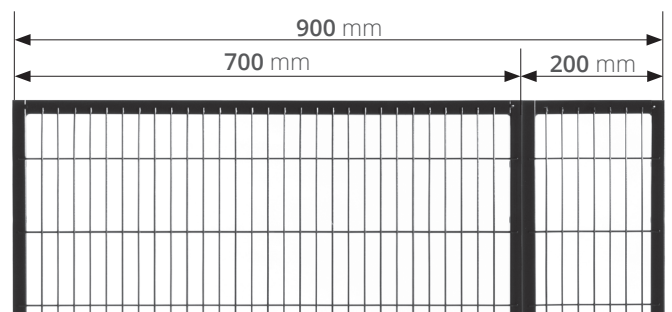

Wire Mesh Panel Detail

Easy to handle, robust, safe

Easy to handle

Light and robust

A resistant and light structure, Satech framed panel can be easily handled by one person

Standard panel sizes:
1900 mm tall (mm)

Width	Part code
200	R020190
300	R030190
700	R070190
800	R080190
1000	R100190
1200	R120190
1500	R150190

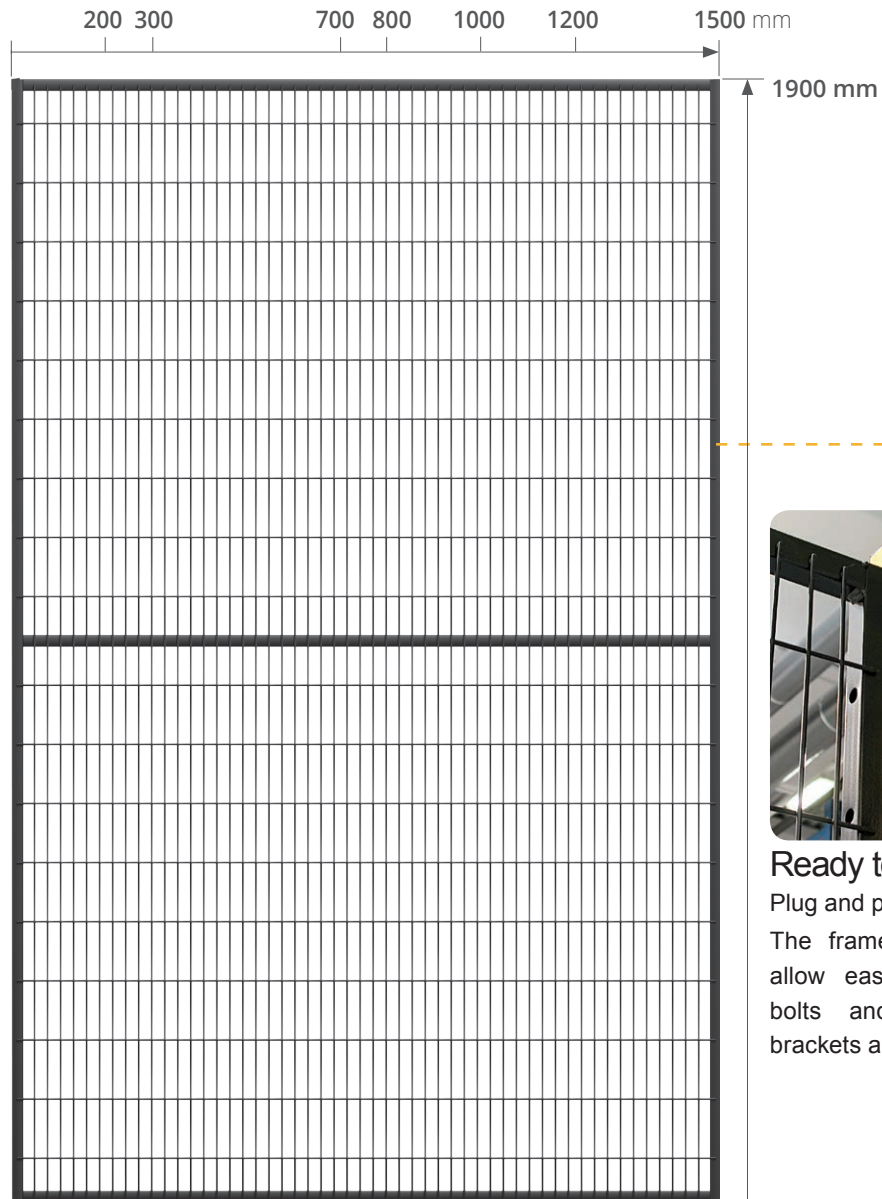

Ready to use

Plug and play versatility

The frame is predrilled to allow easy assembly with bolts and installation of brackets and accessories



Resistant

Wire mesh panel is rigid and resistant, thanks to the welds along the entire frame and at each intersection of the wires. The frame is 20 x 20 mm extruded steel.

Finish:

Epoxy-polyester powder
(suitable for internal use only)

Standard color: ● RAL 9005

Other colors possible, consult factory for custom finishes

Frame profile:
20 x 20 mm

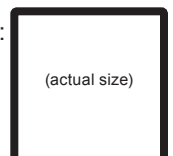

Doors & Accessories



Hinged Doors

Standard hinged door. The movement is achieved by means of two hinges and a door stop, which is provided with a new generation supermagnet. Available as single leaf or double leaf.

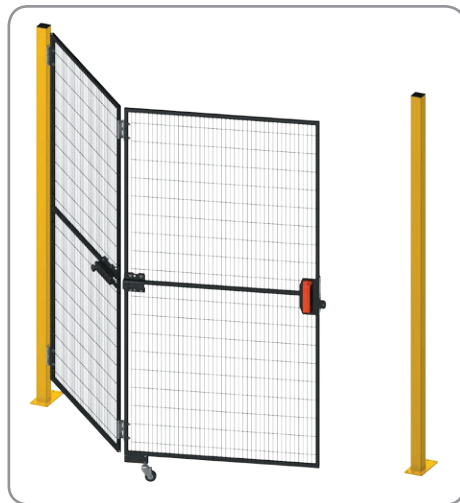

Folding Doors

A folding-hinged door designed to reduce the dimension of the open door. Once the bolt is released, the two leaves fold over one another, reducing the overall size.



Sliding Doors

Sliding panels suspended on an upper track, or panels mounted to low-friction telescopic guides which provide an open passage without height restriction.

A wide variety of other door types are available from factory:

- Sliding doors with lower guide
- Sliding door without guide
- Special large openings
- Hybrid/Combination doors

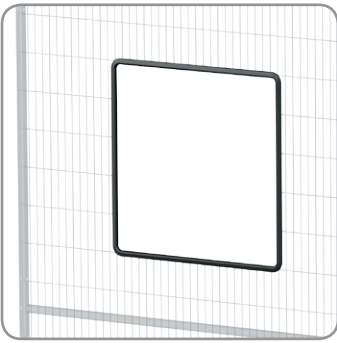

Rubber Profile For Cutouts

Wire mesh panels can be cut on site, for custom openings and around machine parts. This rubber profile provides a nice finish, preventing snagging on jagged cut edges.



Adjustable Angular Joint

Allows the junction between panels and posts with variable angles other than 90°.

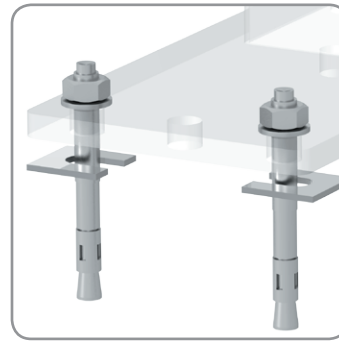

Shims For Posts

U-shaped profile shims to level the posts with ground anchors, without the need to remove the baseplate from the threaded stud of the screw.

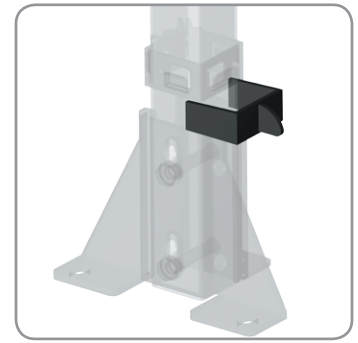

Clamp Spacer

The convenient spacer for a quick and correct positioning of the lower clamp from the ground, according to standards EN 349 - EN ISO 13857 - EN ISO 14120.



Support Swivel Wheel For Doors

New universal support for the housing of a swivel wheel which gives more stability to the door wings. Specifically suitable for hinged doors and some types of sliding doors.

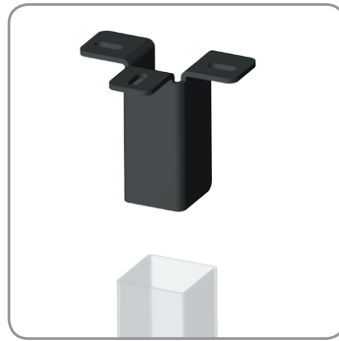

Cable Duct Support Bracket

This fast-coupling cable duct support allows you to fasten the cable duct directly to the post, without the need of any other special bracket.



Reinforced Linear Junction

This accessory is used when two panels need to be unified and extra rigidity is necessary. It also reduces the need for posts, allowing to optimize assembly and material costs.



Post Braces

This 40x40 mm profile post stabilizes upright post that are subjected to horizontal dynamic loads (i.e. due to the operation of large hinged doors) or those that are in unfavorable layout.



Ground Latch

Universal ground latch device which provides greater stability to the closed doors. Suitable for single and double hinged doors, folding doors, and some types of sliding doors.

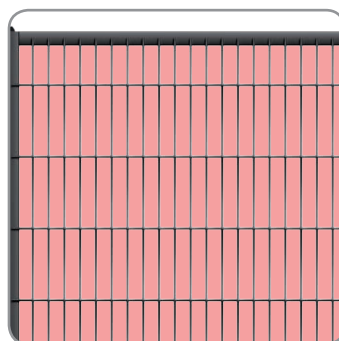

Weld Curtain

A red transparent vinyl curtain, for placement on the wire mesh panels for observation of welding processes. Curtains are sized to match the panel.

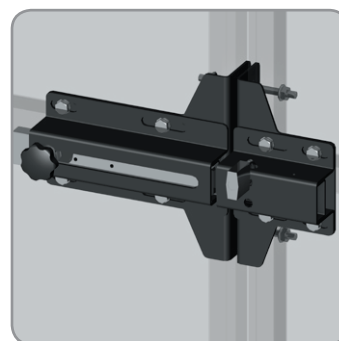

Bracket: Sliding Bolt Lock

System of brackets specifically designed to mount the SATECH bolt lock. Compatible with all double leaf hinged doors and opposed sliding doors



Brackets: SCHMERSAL

Mounting brackets specifically designed to fit SCHMERSAL safety locks and sensors on doors and posts.

Guard monitoring and controls



Monitoring Guard Door Closure



The reason to use machine guards is to keep operators out of hazardous areas around machines when they are in operation. However, access to the hazard area is often necessary for purposes of maintenance, machine actuation, fault clearance, or set-up. Thus the need for guard doors.

Guard doors should be monitored by safety devices and a safety control circuit, where opening a guard will initiate a stop function and the equipment is placed into an interlock state, removing any hazardous situations and preventing a machine cycle, until the guard is closed again. This can be achieved with an electromechanical keyed interlock, a non-contact sensor, or a hinge switch. Safety controllers can be added to the safety circuits to ensure the system will work when called upon by detecting faults, cross-shorts, or component failures.

Guard Door Locks With Emergency Exit



In some applications the guard door needs to be locked instead of just closed. The two main reasons for locking guard doors are to protect a machine process and to protect operators from hazardous areas or conditions which remain after the removal of power. Guards doors protecting these areas need to remain locked until

a fail-safe timer, standstill monitor, safety position sensor, or other suitable safety component determines that a safe state has been reached.

Safety gate switches with solenoid interlocking are used to secure the machine guard doors. They separately monitor door position and locked status to ensure a safe state. The robot standard ANSI/RIA R15.06 requires an emergency release handle which mechanically overrides the solenoid lock from inside the hazardous area, allowing operators to leave – even during a power failure.



Safe Speed & Standstill Monitoring



Sometimes machines may need to be operated outside of normal conditions, such as set-up and parameter setting tasks. A manual enabling device is used and safe speed monitors ensure that the motors do not exceed the maximum prescribed speed.

Standstill monitors ensure that the machine has fully stopped before signaling for guard locks to unlock. There are several methods to detect standstill: back EMF monitoring; safe monitoring of proximity sensors, resolvers, or encoders; and a fail to safe timer for cases where a motor reaches standstill in a consistent amount of time.



Machine Controls and Double Reset



The robot standard ANSI/RIA R15.06 states that every robot shall have an E-Stop. An E-Stop is an easily identifiable red mushroom button mounted on a yellow background which override all controls and initiate a stop in the event of an emergency.

It's not uncommon to put E-Stops and other machine controls near access doors. Controls can select between functions, initiate a controlled shutdown process to unlock the door, can signal machine or guard status, or provide a reset of the safety system.

There may be applications where the entire hazardous area cannot be seen from where the reset control is placed. In these cases a safety relay requiring a double reset is used to ensure the machine is not restarted with personnel in the hazardous area. The process includes pressing a pushbutton inside the affected area, then a safety device on the guard door is actuated (door is closed/locked), and finally a pushbutton on a panel outside the area is pressed, all within a specified timeframe. If the steps are done out of order or are delayed beyond the prescribed time, then the reset process needs to be restarted.



Safety Light Curtains

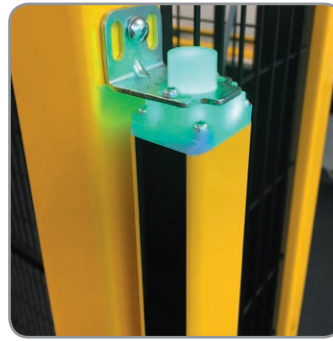

Safety light curtains are a good alternative to doors, especially in higher traffic areas where materials need to regularly pass through the barrier. A safety light curtain is a presence sensing device (PSD) which produces an array of infrared beams between an emitter and a receiver unit. An interruption of the protection field results in a machine stop. They

are available in several resolutions (spacing of beams) to detect fingers (14 mm), hands (30 mm) or bodies (50 mm or greater).

Safety light curtains have several programming functions which allow materials to enter while still preventing operator access.

- Blanking – several beams of the array can be disabled while the remainder of the array is still active. This allows for materials to pass through without tripping a stop, but prevents operators from passing.
- Muting – sensors detect the approach of pallets and disengage all or part of the array to allow them to move through. The loaded pallet's presence blocks access during the transition and the field is restored when the pallet is no longer blocking the way.

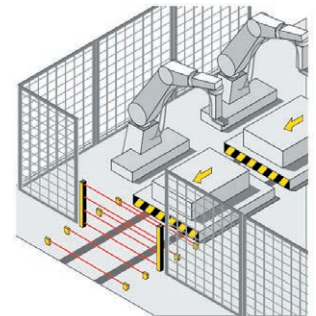
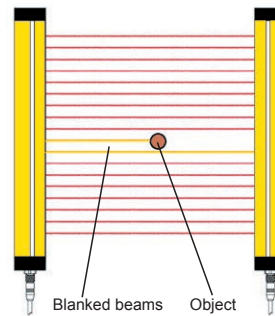

Safety light curtains can also be used in a double reset process, where interrupting the protection field as the worker exits the hazardous area comes between the two pushbutton actuations.



Relevant standards

EN ISO 14120 General requirements for the design and manufacture of fixed and movable guards.

5.2.4 - Viewing

Where viewing of the process is required, guards shall be designed and constructed to offer adequate viewing.

5.9 - Machine viewing

Where viewing of machine operation is required through the guard, materials shall be selected with suitable properties (...) or wire mesh is used, this should be of adequate open area and suitable colour to permit viewing. Viewing will be enhanced if the perforate material is darker than the area observed.



EN ISO 13857, 4.2.2: Reaching over protective structures

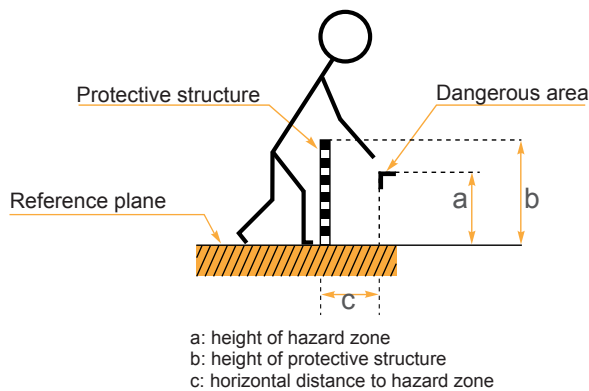

Table 2 Dimensions in millimeters

Height of dangerous area a	Height of the protection structure b									
	1000	1200	1400	1600	1800	2000	2200	2400	2500	2700
Horizontal distance to the dangerous area c										
2700	-	-	-	-	-	-	-	-	-	-
2600	900	800	700	600	600	500	400	300	100	-
2400	1100	1000	900	800	700	600	400	300	100	-
2200	1300	1200	1000	900	800	600	400	300	-	-
2000	1400	1300	1100	900	800	600	400	-	-	-
1800	1500	1400	1100	900	800	600	-	-	-	-
1600	1500	1400	1100	900	800	500	-	-	-	-
1400	1500	1400	1100	900	800	-	-	-	-	-
1200	1500	1400	1100	900	700	-	-	-	-	-
1000	1500	1400	1000	800	-	-	-	-	-	-
800	1500	1300	900	600	-	-	-	-	-	-
600	1400	1300	800	-	-	-	-	-	-	-
400	1400	1200	400	-	-	-	-	-	-	-
200	1200	900	-	-	-	-	-	-	-	-
0	1100	500	-	-	-	-	-	-	-	-

EN ISO 13857, 4.2.4.1: Reaching through regular openings



Table 4 gives S_r for regular openings for persons of 14 years of age and above.

The dimension of the opening “e” corresponds to the side of a square opening, the diameter of a round opening and the narrowest dimension of a slot opening.

For openings larger than 120 mm safety distances in accordance with point 4.2.2 shall be used.

Table 4 Dimensions in millimeters

Part of body	Illustration	Opening	Safety distance S_r		
			Slot	Square	Round
Fingertip		$e \leq 4$	≥ 2	≥ 2	≥ 2
		$4 < e \leq 6$	≥ 10	≥ 5	≥ 5
Finger up to knuckle joint		$6 < e \leq 8$	≥ 20	≥ 15	≥ 5
		$8 < e \leq 10$	≥ 80	≥ 25	≥ 20
Hand		$10 < e \leq 12$	≥ 100	≥ 80	≥ 80
		$12 < e \leq 20$	≥ 120	≥ 120	≥ 120
Arm up to junction with shoulder		$20 < e \leq 30$	$\geq 850^a$	≥ 120	≥ 120
		$30 < e \leq 40$	≥ 850	≥ 200	≥ 120
		$40 < e \leq 120$	≥ 850	≥ 850	≥ 850

The bold lines within the table indicate the part of the body which is restricted by the opening size.
a) If the length of the slot opening is less or equal to 65 mm, the thumb will act as a stop and the safety distance can be reduced to 200 mm.

EN ISO 13857, 4.3: Safety distances to prevent access by lower limbs

In general, safety distances should be determined using Tables 1 to 6 for the upper limbs.

When it is not possible to foresee the upper limb access through the opening, it is possible to use the values given in Table 7 to determine safety distances for the lower limbs.

The dimension “e” of openings corresponds to the side of a square opening, the diameter of a round opening or the narrowest dimension of a slot opening.

The values given in Table 7 are independent of whether clothing or footwear is being worn and are applicable for persons of 14 years of age and above. For reaching through openings of irregular shape, see 4.2.4.3.

Table 7

Part of lower limb	Illustration	Opening	Dimensions in millimeters	
			Safety distance S_r Slot	Safety distance S_r Square or round
Toe tip		$e \leq 5$	0	0
		$5 < e \leq 15$	≥ 10	0
Toe		$15 < e \leq 35$	$\geq 80^a$	≥ 25
		$35 < e \leq 60$	≥ 180	≥ 80
Foot		$60 < e \leq 80$	$\geq 650^b$	≥ 180
		$80 < e \leq 95$	$\geq 1100^c$	$\geq 650^b$
Leg (toe tip to knee)		$95 < e \leq 180$	$\geq 1100^c$	$\geq 1100^c$
		$180 < e \leq 240$	not admissible	$\geq 1100^c$

a) If the length to the slot opening is ≤ 75 mm, the distance can be reduced to ≥ 50 mm

b) The value corresponds to leg (toe tip to knee)

c) The value corresponds to leg (toe tip to crotch)

Note: Slot openings with $e > 180$ mm and square or round openings with $e > 240$ mm will allow access for the whole body (see also Clause 1, final paragraph)

EN ISO 14120: Impact test

Our protections Series BASIC and STRONG, assembled with nuts and bolts, have been subjected to severe dynamic resistance tests from the inside outwards according to the procedure contained in EN ISO 14120 Standard (Hard body / Pendulum Test).

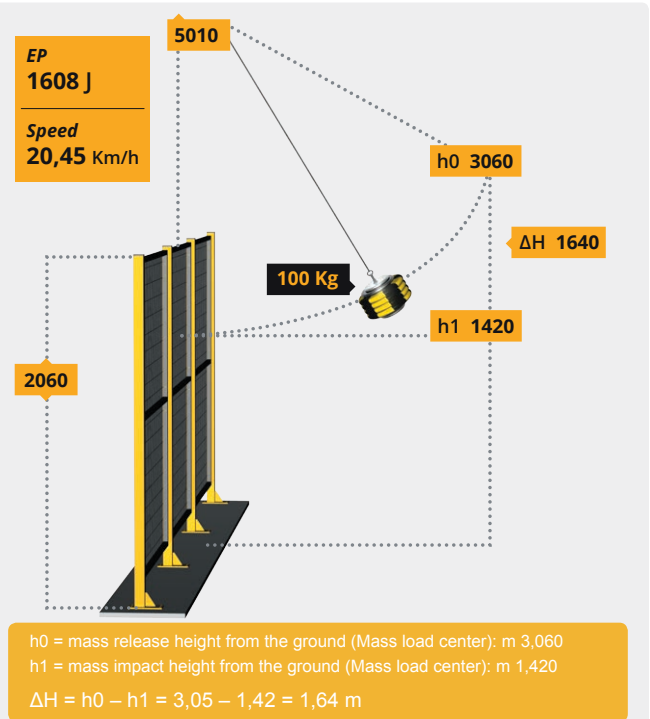

Additional relevant standards:

EN ISO 12100 Basic concepts, general design principles.

EN ISO 13857 Safety distances to prevent the contact of dangerous areas with upper and lower limbs.

EN 349 - ISO 13854 Minimum gaps to avoid crushing parts of the human body.

EN ISO 10218-2 Industrial handling robots. Safety.

EN ISO 14119 Interlocking devices designed for guards. Design and selection concepts.

Schmersal USA

15 Skyline Drive
Hawthorne, New York 10532
www.schmersalusa.com



Contact: Joshua Fincher
Phone (347) 860-1806
jfincher@schmersal.com

Schmersal Canada

29 Centennial Road, Unit 1
Orangeville, Ontario L9W 1R1
www.schmersalcanada.ca